



*Gaiarekin bat eginda
Sumamos en Gaia*

Convergencia para la Smartización





Responsabilidad GAIA- Crear REDES



THE FRAMEWORK PROGRAMME FOR RESEARCH AND INNOVATION

HORIZON 2020



Hay muchas experiencias que compartir en GAIA



Reuniones Territoriales



Firma de Convenios-Acuerdos



Reuniones Territoriales

¿QUÉ SIGNIFICA "FACTORIES OF FUTURE" O "SMART MANUFACTURING"?



Ciudades Inteligentes

Publicaciones Sectoriales



Fabricación Avanzada



BATZAR BROKORRA ASAMBLA GENERAL 2014

PROGRAMA DE LICENCIACIONES INTERNACIONALES



78 profesionales

Interesados en formar parte del centro de expertos

12 propuestas

2 de suministros
10 de Asistencia Técnica.
Países: Vietnam, China, Nepal, Perú, Colombia, México, Armenia, Jamaica, Perú + Bangladesh, India, Pakistan

- 3 Intercambios tecnológicos: Colombia (2), Rumanía (Bangladesh, India, Pakistan, China (1), Vietnam, China (1))
- 2 eventos educativos: Rep. Dominicana y Colombia
- 10 empresas innovadoras directa o indirectamente
- Promoción de capacitaciones y del Centro de Expertos, en 15 agencias ejecutoras, 6 escuelas, 22 entidades, 1088 beneficiarios y 14 colaboraciones
- 1 Reconocimiento de Suministros y Asistencia Técnica en colaboración con empresas de GAMA en la Smart City de Barcelona



PROGRAMA DE FOMOS EN TECNOLOGÍA

BATZAR BROKORRA ASAMBLA GENERAL 2014



PROGRAMAS SECTORIALES DE APOYO AL I+D+i



25 Propuestas

Potenciar la participación de las Empresas Asociadas en proyectos en colaboración

dentro del marco de la Comisión Europea y otros programas de apoyo





La propia experiencia Cluster, su forma de trabajo es una oportunidad

Seguimiento, Monitorización y Difusión de:

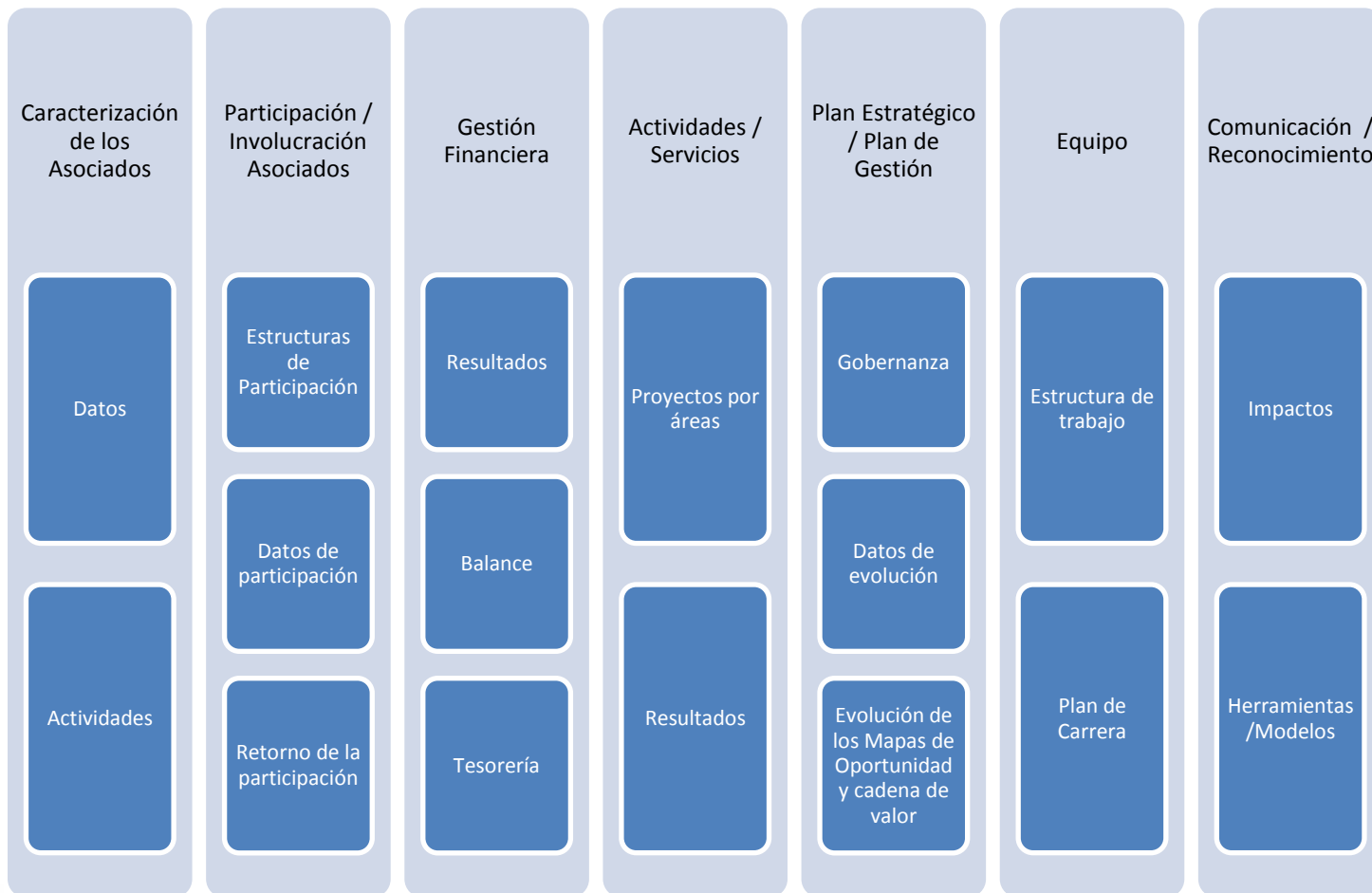

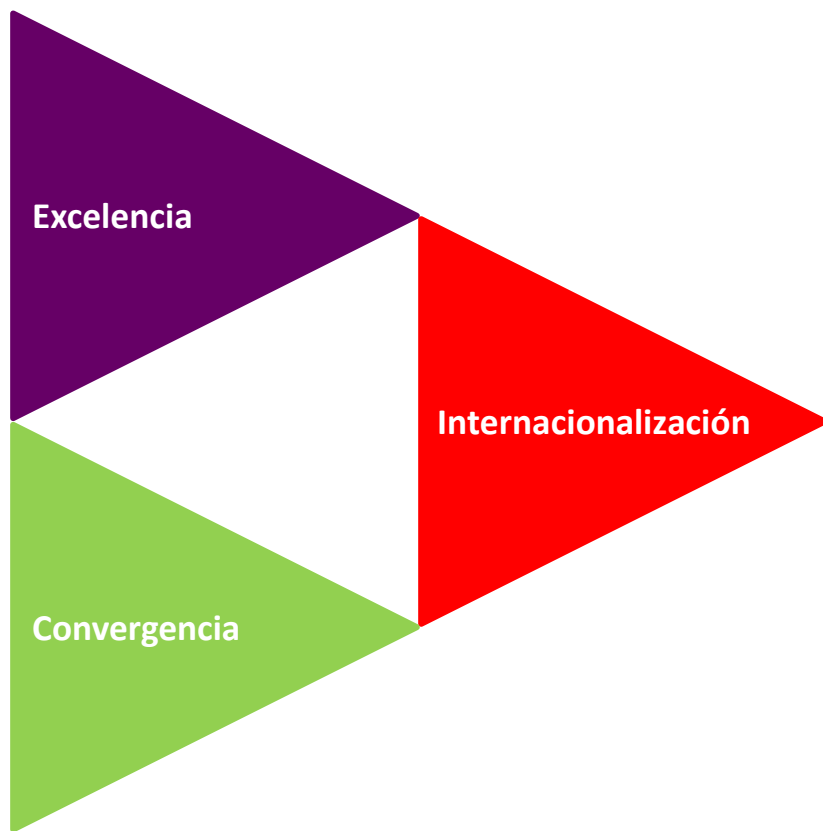

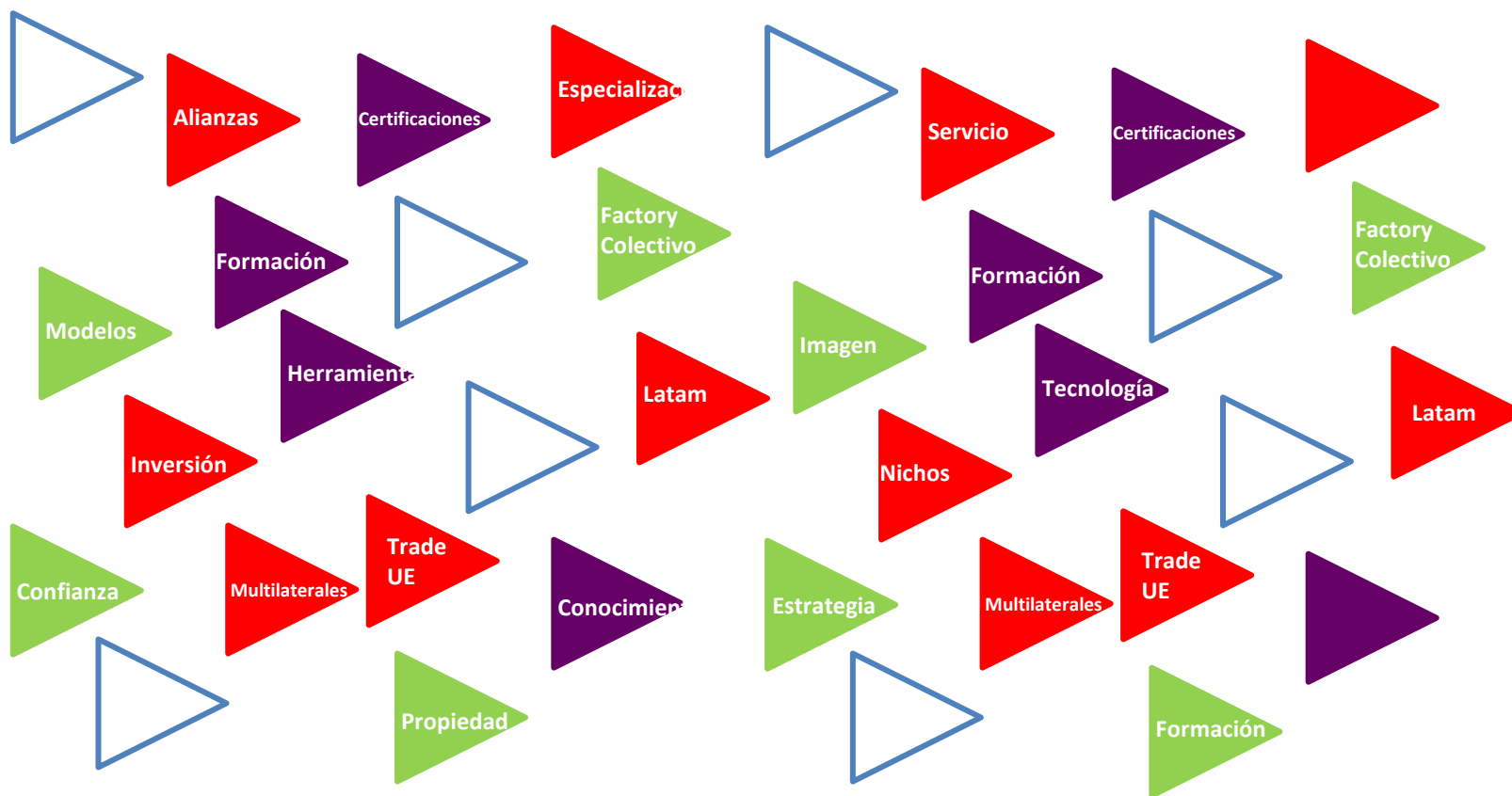



Que buscamos con esta experiencia?

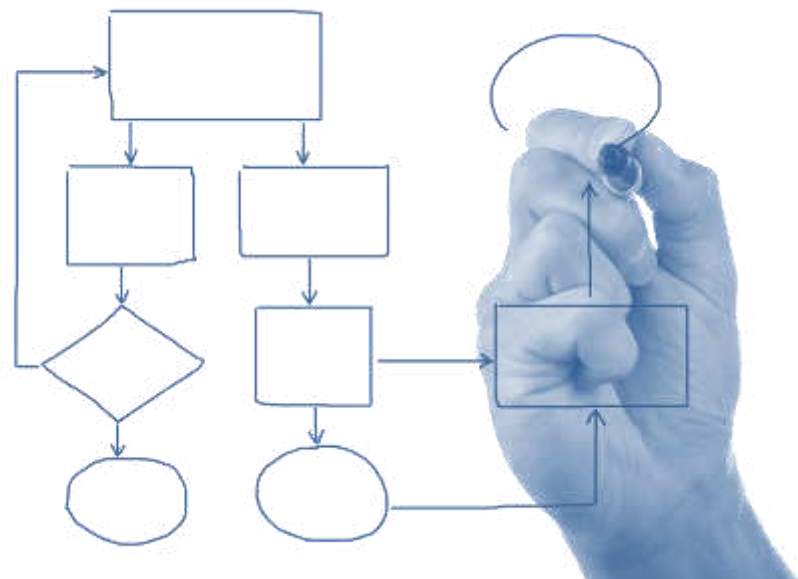

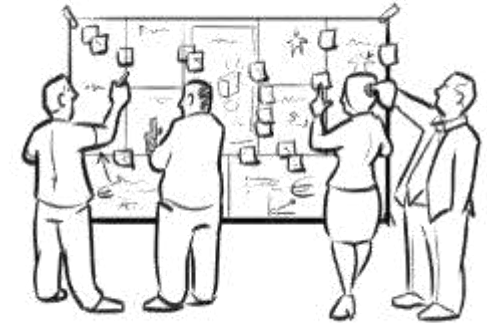
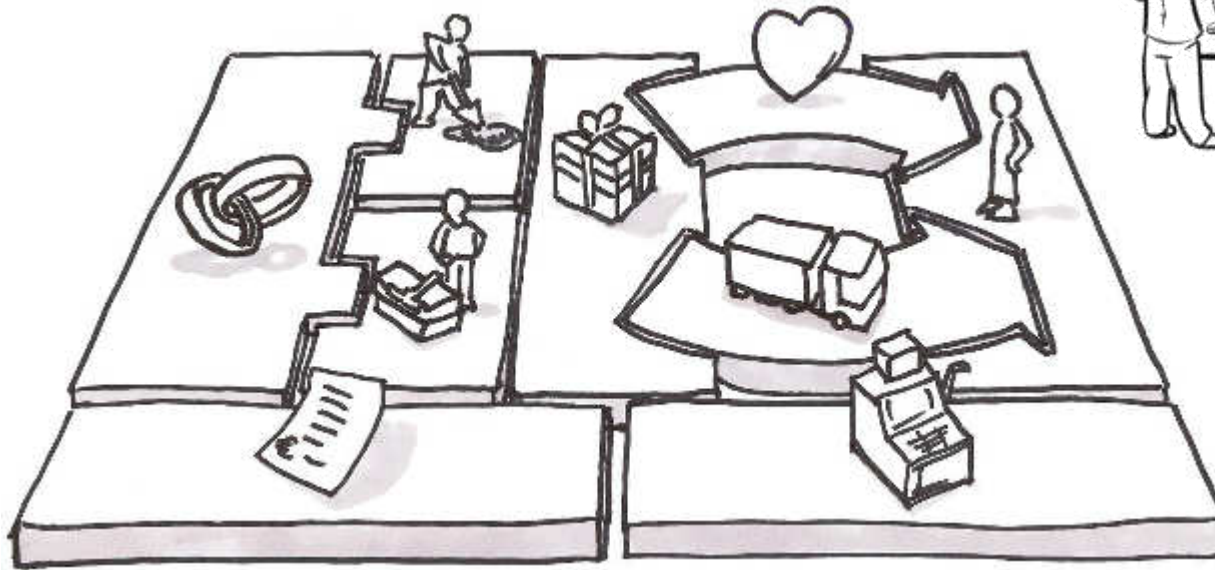

Nuevos Modelos de Negocio/Servicio





Especialización



Evolucionar la Oferta



Innovación



Para avanzar rápido hay que

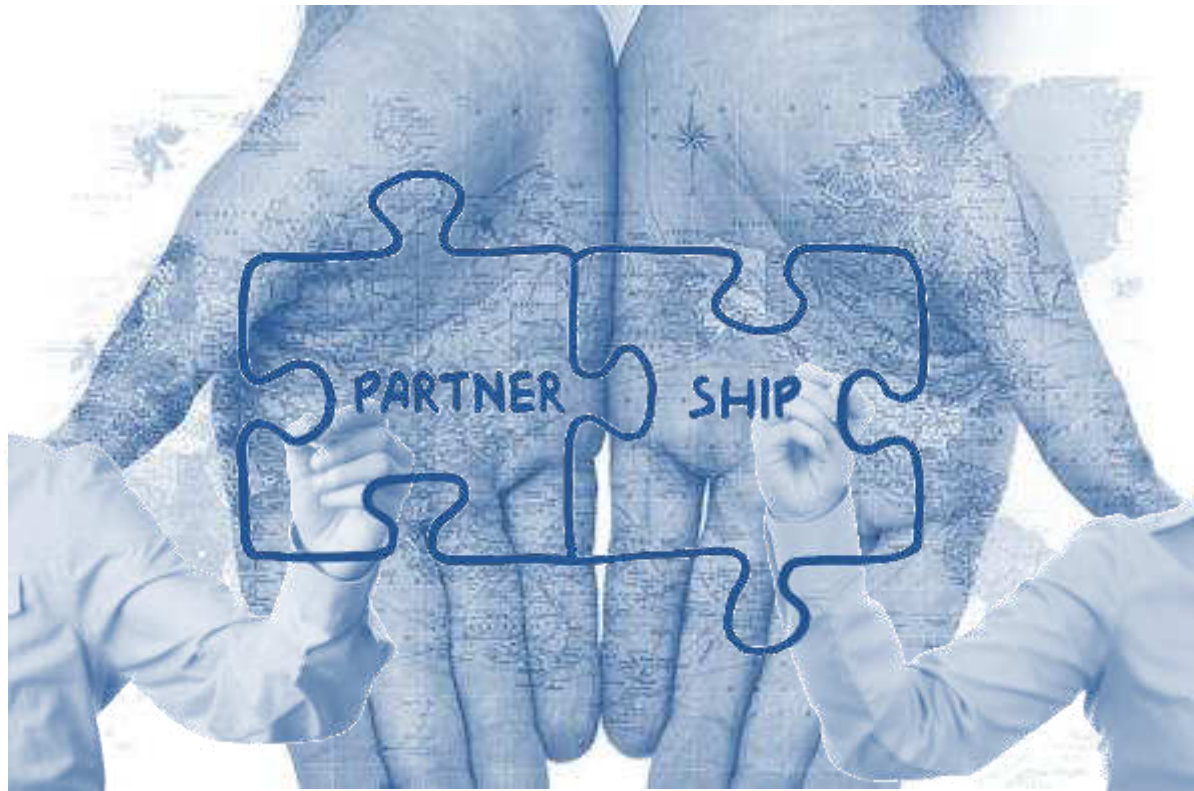

Reforzar Alianzas



Generar Confianza





La Colaboración Internacional permite una



Internacionalización estructurada



Donde estamos trabajando?







Territorio Inteligente



Energía Sostenible



Salud y Personas



Fabricación Avanzada

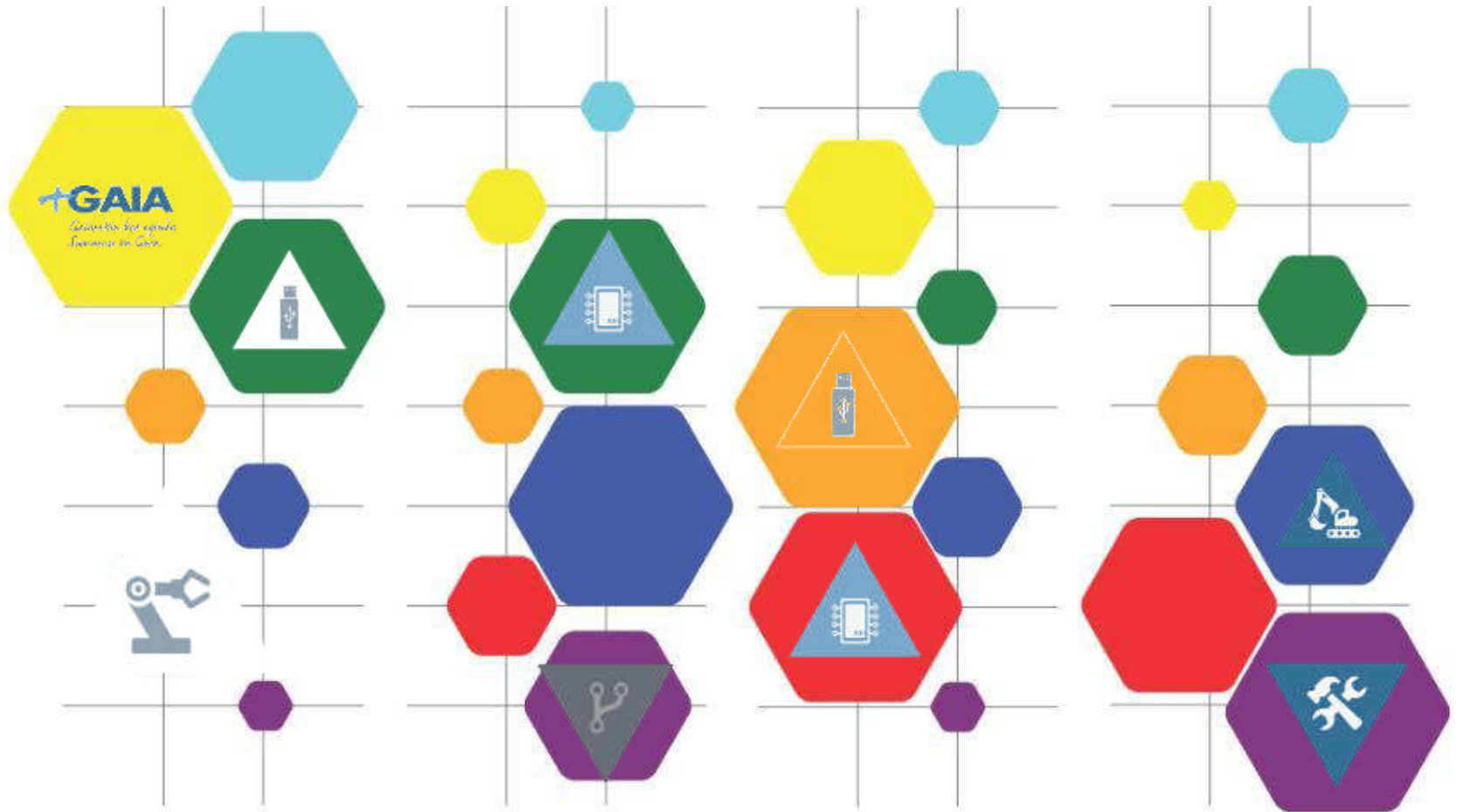



MODELOS DE TRABAJO A CONSTRUIR





Construir nuevas Soluciones para el Mercado Global



Trabajar Juntos ente el reto del Mercado Global



Proyectos Referente



Personas mayores,
enfermos crónicos
pluripatológicos
que requieren
atención especial.



Análisis Local
Proactivo



Personalizado
Ubicuidad

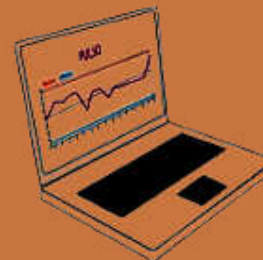

Seguimiento
Personalización
Tiempo Real



Profesionales
sanitarios,
cuidadores,
familiares...

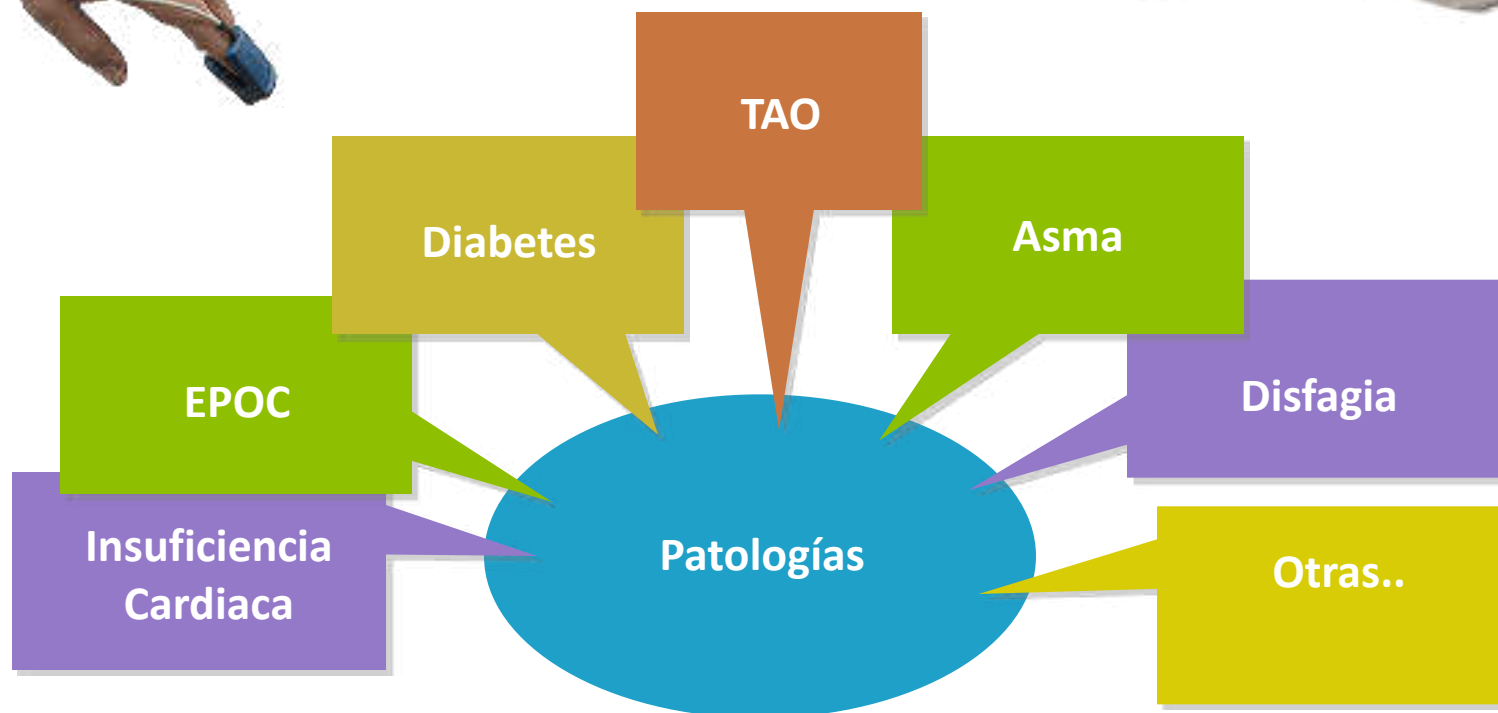



Saludnova - Microsoft Internet Explorer

https://www.saludnova.com/extranet/centros/mediciones/index.php

Buscador de mediciones

Desde: [] - [] - [] Hasta: [] - [] - []

Mediciones: 10 Últimas 20 Últimas 50 Últimas Todas

*Usuario: TELBIL55

Últimas mediciones

Fecha de cita	Usuario
2010-07-08 11:08:54	TELBIL55
2010-06-28 09:46:28	TELBIL45

TEL BIL 55

Inicio Perfil

FEBO PULSO RESPIR SPO2 TEMP TENSIO CUES

Últimas mediciones

MEDIDAS	10-07-08 11:08:54	10-07-07 10:57:50	10-07-06 11:21:47	10-07-05 11:24:10
PESO	74	74	74	74
PULSO	75	77	85	77
RitmoResp	24	24	24	24
SPO2	92	91	91	90
TEMPERATURA	35	35	34.50	34.50
TENSION (Diastólica)	95	84	84	82
TENSION (sistólica)	88	110	110	110
CUESTIONARIO	var	Var	var	Var

SPO2

SPO2

Fecha	Valor
2010-07-08 11:08:54	92
2010-07-07 10:57:50	91
2010-07-06 11:21:47	91
2010-07-05 11:24:10	90
2010-07-03 11:21:05	90
2010-07-02 11:16:52	90
2010-07-01 11:21:33	91
2010-06-30 10:02:23	91
2010-06-29 11:12:37	92
2010-06-28 10:14:59	90

Família
Igualdade
Saúde
Bem-estar
Educação
Identidade
Proteção
Primeira infância
Jogo
Participação







Installed Items

- **Renewable Energy**

PV Generation (Crystalline panels)

Vertical Micro Wind Turbine **NEW**

Horizontal Micro Wind Turbine

Fuell Cell **NEW**

- **Traditional Generation**

Diesel Generator

- **Cogeneration**

Gas Turbine

- **Storage Technologies**

Lead Battery

Li-ion Battery **NEW**

Super Capacitors **NEW**

Fly Wheel **NEW**

NEW



- **ICT Technologies**

Intelligent Management

Distributed Control



- **Electric Vehicle **NEW****

Recharging points



NEW

- **Remote management of residential load**

Rates

Demand management

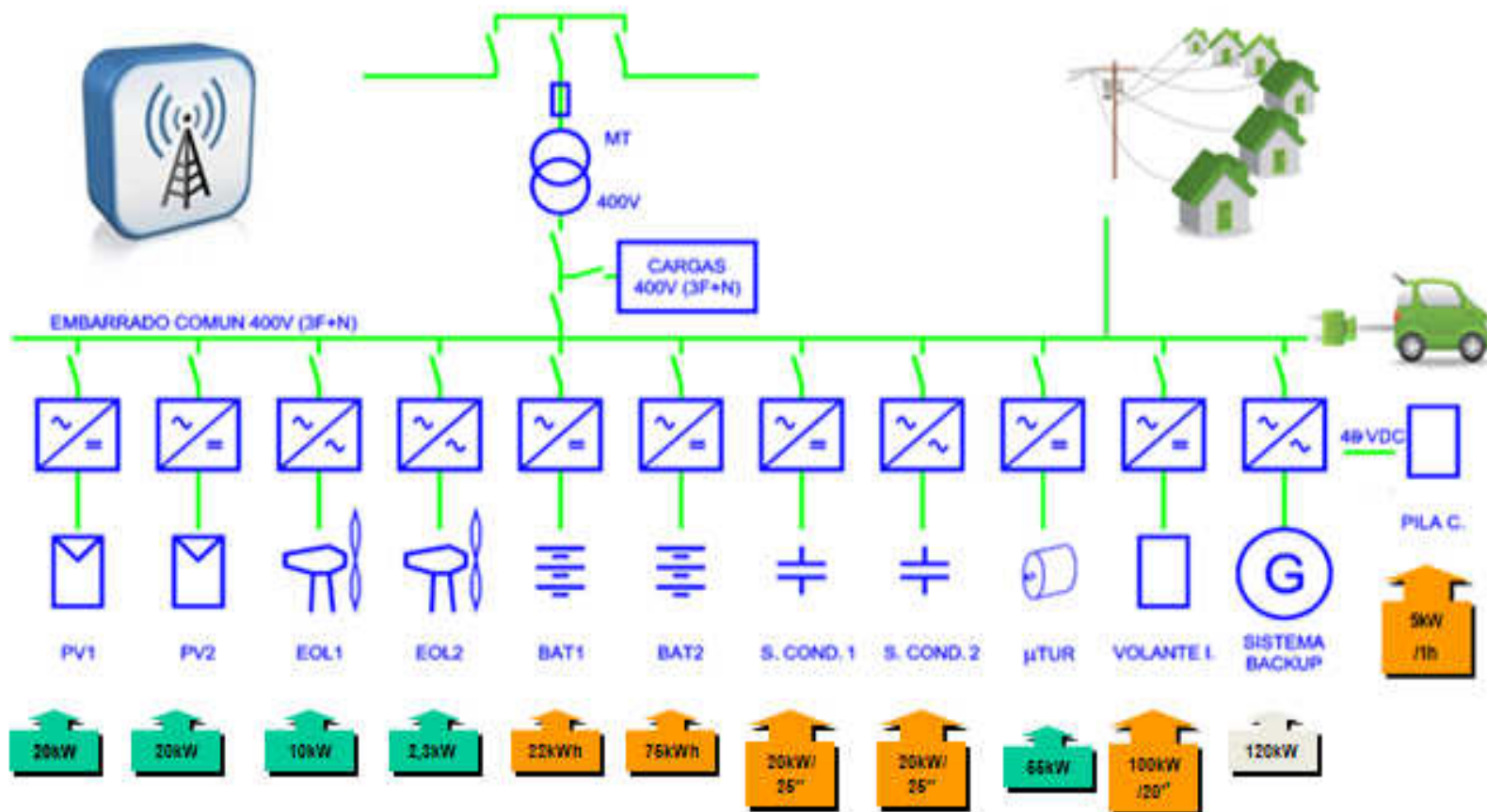

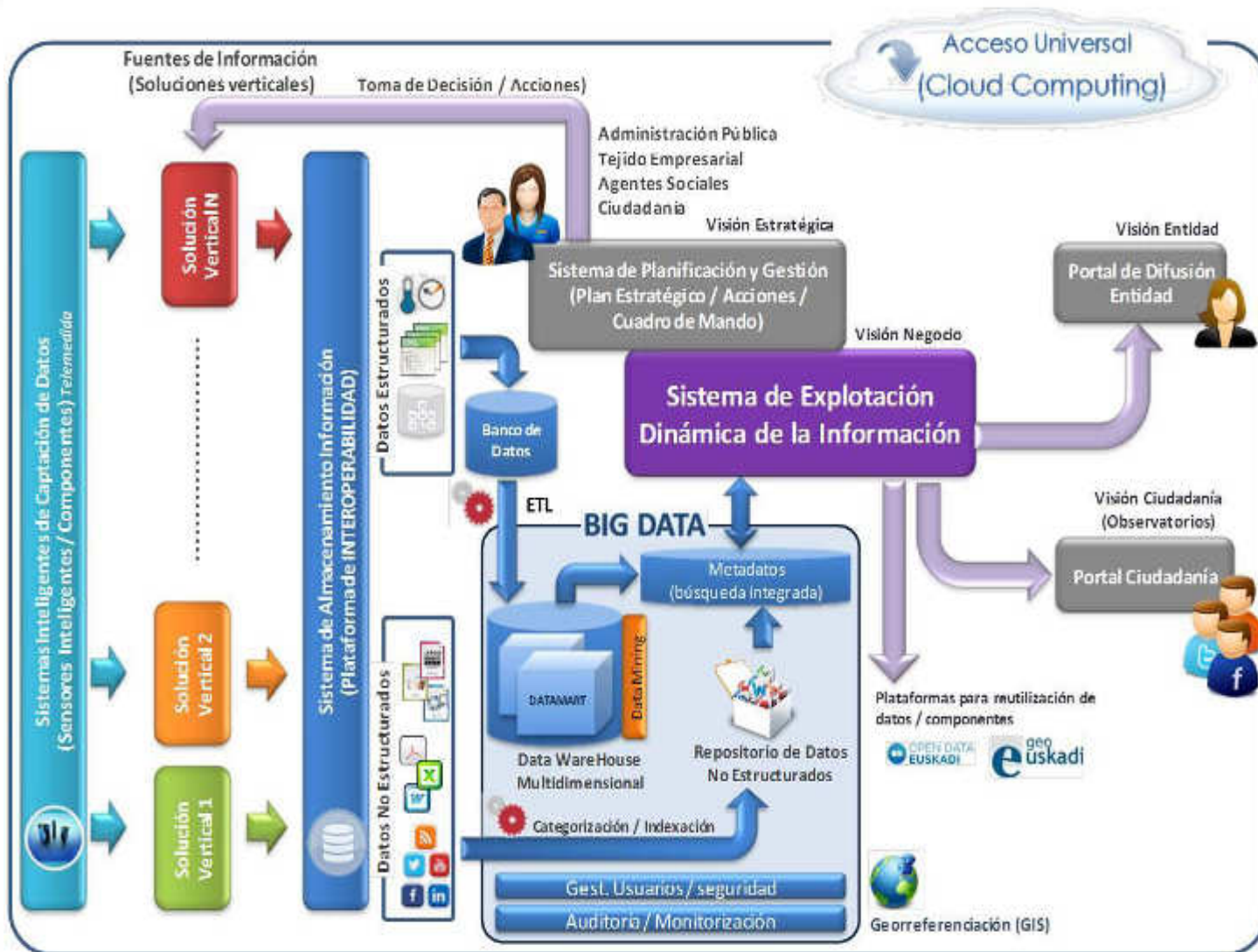



POWERTRAIN CONCEPT

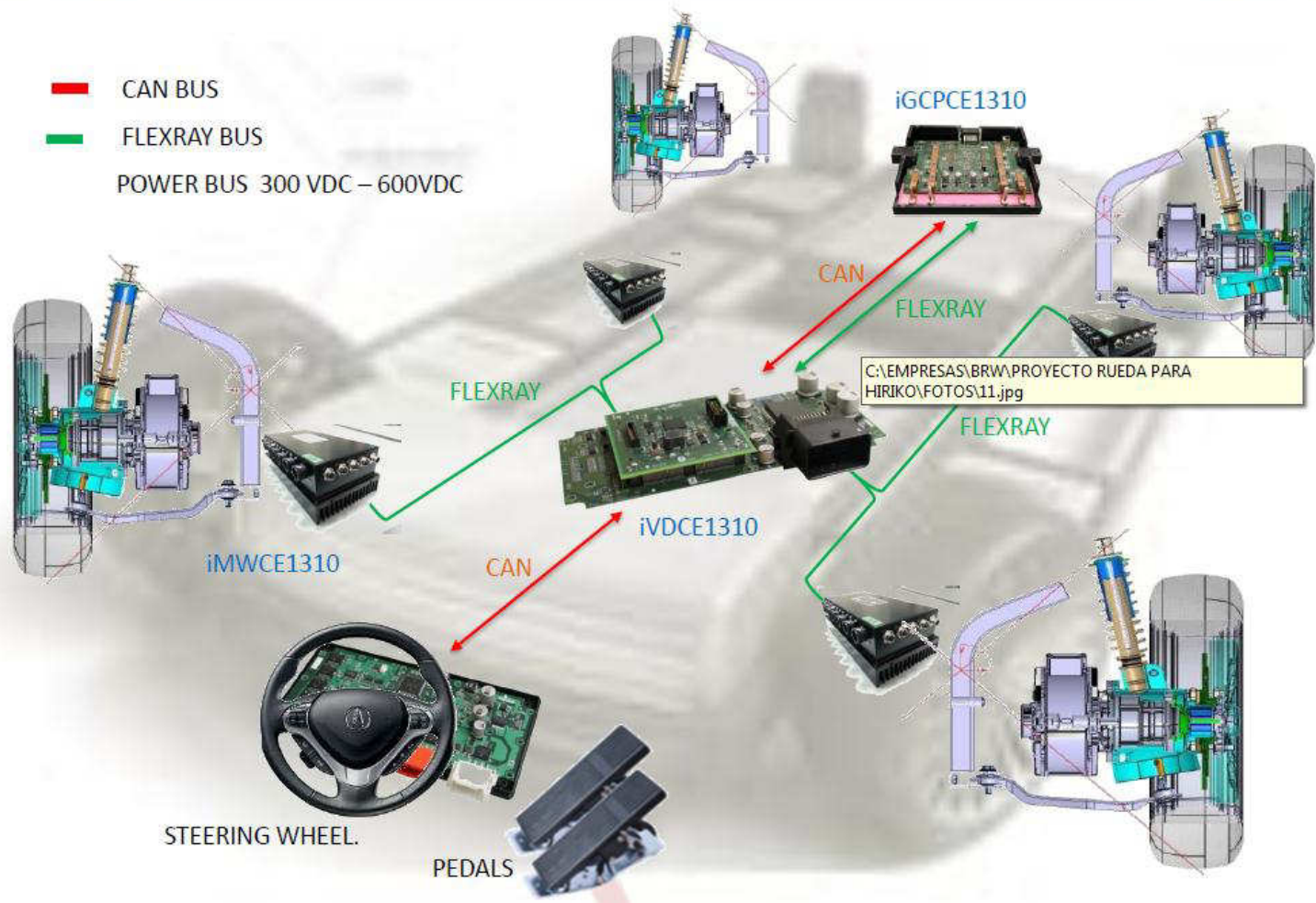



INICIO

educación

Arte

Deporte

Empresa

Contacto

Search

Thinking differently





Gracias